

Model 7100A Accelerometer



+150°C IEPE Accelerometer
Wide Bandwidth to 15kHz
Hermetically Sealed
Through Hole Mount



The **Model 7100A** is a high performance IEPE accelerometer with an operating temperature range of -55°C to +150°C. The accelerometer is available in ± 50 to $\pm 500g$ ranges and provides a flat frequency response up to 15kHz. The model 7100A is hermetically sealed and features the popular through hole mount installation for use with standard mounting screws.

dimensions

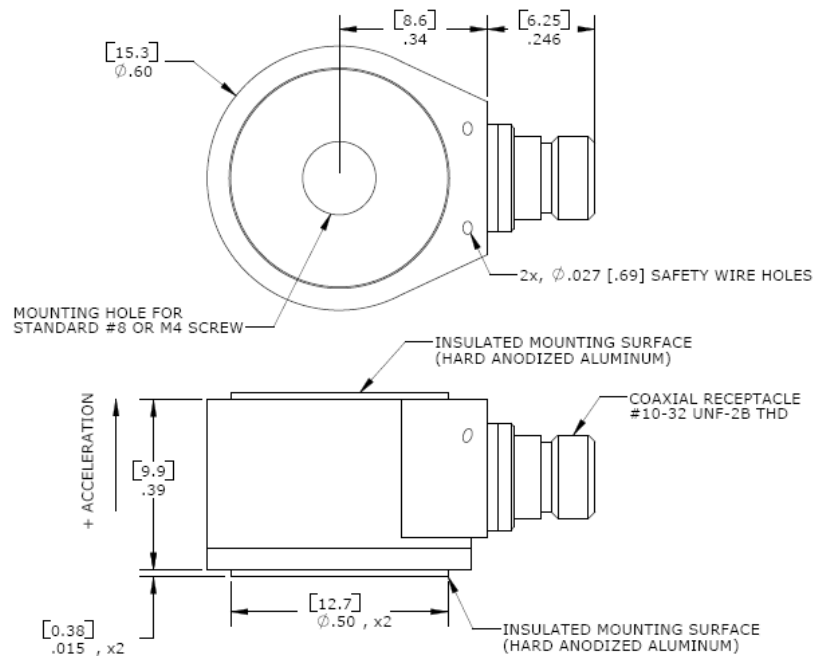

FEATURES

- $\pm 50g$ to $\pm 500g$ Dynamic Range
- Wide bandwidth up to 15kHz
- Through Hole Mount
- Hermetically Sealed
- Annular Shear Mode
- Isolated Mounting Surface
- Stable Temperature Response
- TEDS Option

APPLICATIONS

- Vibration & Shock Monitoring
- High Temp IEPE Applications
- Flight Testing
- Gearbox Vibration Monitoring
- High Frequency Applications
- HUMS

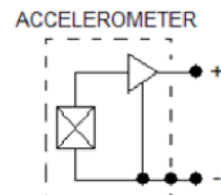

Model 7100A Accelerometer

performance specifications

All values are typical at +24°C, 100Hz and 4mA excitation unless otherwise stated. Measurement Specialties reserves the right to update and change these specifications without notice. Standard product parameters are described in PSC-1003 for Plug & Play AC Accelerometers.

Parameters

			Notes
DYNAMIC			
Range (g)	±50	±500	
Sensitivity (mV/g)	100	10	±10%
Frequency Response (Hz)	1-5000	1-7000	±5%
Frequency Response (Hz)	0.5-10000	0.5-15000	±1dB
Natural Frequency (Hz)	33000	43000	
Non-Linearity (%FSO)	±1	±1	
Transverse Sensitivity (%)	<5	<5	
Shock Limit (g)	5000	5000	
ELECTRICAL			
Compliance Voltage (Vdc)	18 to 30	18 to 30	
Excitation Current (mA)	2 to 20	2 to 20	
Bias Voltage (Vdc)	8 to 12	8 to 12	Room Temperature
Bias Voltage (Vdc)	6 to 14	6 to 14	-55 to +150°C
Output Impedance (Ω)	<100	<100	
Full Scale Output Voltage (V)	±5	±5	
Residual Noise (g RMS)	0.0001	0.00025	Broadband 1Hz to 10kHz
Discharge Time Constant (sec)	0.8 to 1.2		
Warm-Up Time (sec)	2		
Grounding	Isolated from Mounting Surface		
ENVIRONMENTAL			
Temperature Response (%)	See Typical Temperature Response Curve		
Operating Temperature (°C)	-55 to +150		See Note 1
Storage Temperature (°C)	-55 to +150		See Note 1
Humidity	Hermetically Sealed		
PHYSICAL			
Sensing Element	Ceramic (shear mode)		
Case Material	Stainless Steel		
Electrical Connector	10-32 Coaxial Receptacle		
Weight (grams)	11		
Mounting	Through Hole (#8 or M4 cap screw)		
Mounting Torque	16 lb-in (1.8 N-m)		

¹ Contact factory for +175°C temperature option.

Calibration supplied:	CS-FREQ-0100	NIST Traceable Amplitude Calibration from 20Hz to ±1dB Frequency Response Limit
Supplied accessories:	AC-D02787	1x #8-32 Mounting Screw (5/8 inch length)
Optional accessories:	310-XXX	Cable Assembly, 10-32 to 10-32 (XXX designates length in inches, 10ft standard)
	314-XXX	Cable Assembly, 10-32 to BNC (XXX designates length in inches, 10ft standard)
	AC-A03389	Triaxial Mounting Block
	AC-A03388	Adhesive Mounting Adaptor
	AC-A03472	Magnetic Mounting Adaptor

The information in this sheet has been carefully reviewed and is believed to be accurate; however, no responsibility is assumed for inaccuracies. Furthermore, this information does not convey to the purchaser of such devices any license under the patent rights to the manufacturer. Measurement Specialties, Inc. reserves the right to make changes without further notice to any product herein. Measurement Specialties, Inc. makes no warranty, representation or guarantee regarding the suitability of its product for any particular purpose, nor does Measurement Specialties, Inc. assume any liability arising out of the application or use of any product or circuit and specifically disclaims any and all liability, including without limitation consequential or incidental damages. Typical parameters can and do vary in different applications. All operating parameters must be validated for each customer application by customer's technical experts. Measurement Specialties, Inc. does not convey any license under its patent rights nor the rights of others.

Model 7100A Accelerometer

performance specifications

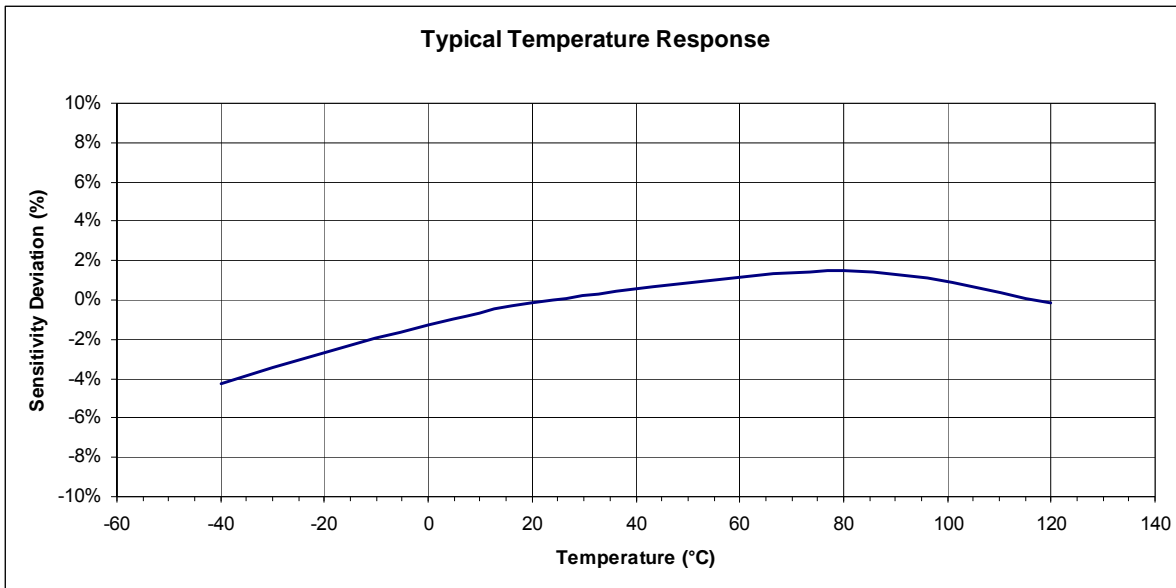
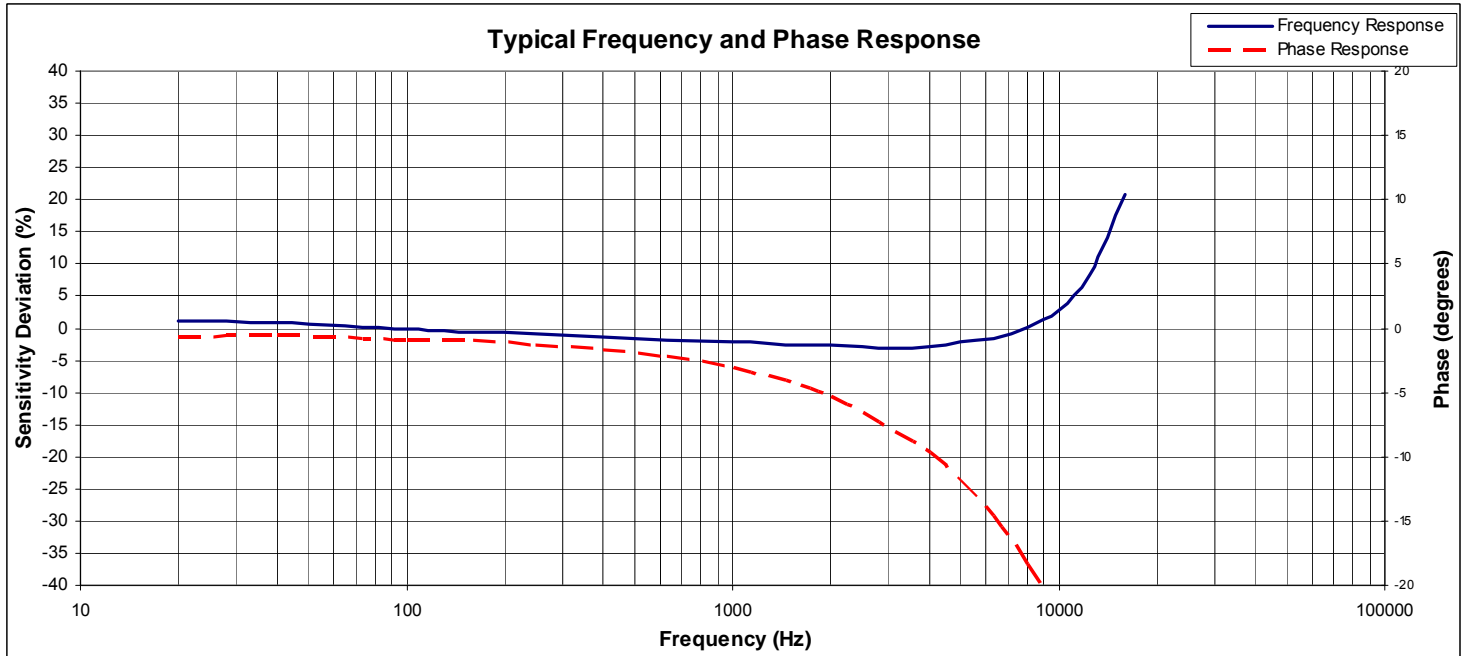

ordering info

PART NUMBERING Model Number+Range

7100AT-GGGG

| | Range (0050 is 50g)

| TEDS compliant to IEEE 1451.4 when 'T' option is included

Example: 7100A-0050
Model 7100A, 50g

北京汇润科贸有限公司

电话: +86 010 5601 8989

+86 010 5601 7979

传真: +86 010 5885 7266

邮箱: sales@aq315.com

<http://www.aq315.com>