

FA101 Accelerometer

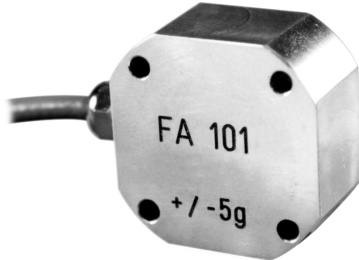

- Full Scale range ± 2 g to ± 500 g
- DC Response
- Integrated Over-range Stops
- Solid State Reliability
- High Level Output Model with Integrated Amplifier

DESCRIPTION

The FA101 is a general purpose accelerometer which is especially useful for measuring low-level ranges. Packaged in a rugged metal case, the FA101 accelerometers are designed for easy handling to suit a wide range of environmental conditions. They are also available with built-in A1/A2 module, providing internal signal conditioning.

With many years of experience as a designer and manufacturer of sensors, Measurement Specialties Inc. has the expertise to customize and/or design sensors for specific uses and testing environments. To meet your needs we also offer complete turnkey systems. Our conditioning electronics can power the sensor, amplify the electronic signal, and display the data digitally. A turnkey measurement system arrives with matched components, formatted, calibrated and ready for your immediate use.

FEATURES

- Full Scale Range ± 2 g to ± 500 g
- DC Response
- Integrated Over-range Stops
- Solid State Reliability
- High Level Output Model with Integrated Amplifier

APPLICATIONS

- Structure vibration analysis and control
- Monitoring of machinery
- Robotics and effectors
- Laboratory and Research

STANDARD RANGES

Measurement Range (g)	± 2	± 5	± 10	± 20	± 50	± 100	± 200	± 500
Over-range (g)	400	400	400	400	1000	2000	2000	2000
Frequency Response $\pm 5\%$ (Hz) FA101/FA101-24/FA101- A2	0-200	0-250	0-300	0-500	0-750	0-1000	0-1200	0-1250
Frequency Response $\pm 5\%$ (Hz) FA101-A1	0-100	0-150	0-250	0-400	0-700	0-700	0-700	0-700
Frequency Response $\pm 5\%$ (Hz) FA101-A3	0-200	0-250	0-300	0-500	0-750	0-1000	0-1000	0-1000

FA101 Accelerometer

PERFORMANCE SPECIFICATIONS

Ambient Temperature: 20±1°C (unless otherwise specified)

Parameters	
Operating Temperature Range (OTR)	-20 to 80° C (-4 to 176°F)
Compensated Temperature Range (CTR)	0 to 60° C (32 to 140°F)
Zero Shift in CTR	< 2 % F.S./ 50° C (100°F)
Sensitivity Shift in CTR	< 2 % of reading 50° C (100°F)
Range (F.S.)	± 2 to ± 500g
Over-Range	From 400-2000g
Accuracy	
Non-Linearity	<±2% F.S.
Transverse Sensitivity	<3%

Electrical Characteristics

Model	FA101	FA101-24	FA101-A1	FA101-A2	FA101-A3
Supply Outage	10Vdc	14 – 36Vdc	10 to 30Vdc	±15Vdc	12 to 36Vdc
F.S. Output	±20 to ±100mV	±20 to ±100mV	±2V(±250mV)	±5V±5%F.S	4 to 20mA
Zero Offset	<±10mV	<±10mV	2.5V(±250mV)	0V±5%F.S.	12mA±5%F.S.
Input Impedance	10kΩ	10kΩ	<30mA	-	-
Output Impedance	<5kΩ	<5kΩ	<90Ω	-	-
Insulation under 50Vdc	≥100MΩ	≥100MΩ	≥100MΩ	≥100MΩ	≥100MΩ

Notes

1. Electrical Termination: Cable gland termination; 2 m [6.5ft]cable length standard
2. Material: Housing in aluminum alloy
3. Weight w/o cable: <25g [0.055 lb]

FA101 Accelerometer

DIMENSIONS & WIRING SCHEMATIC (IN METRIC AND IMPERIAL)

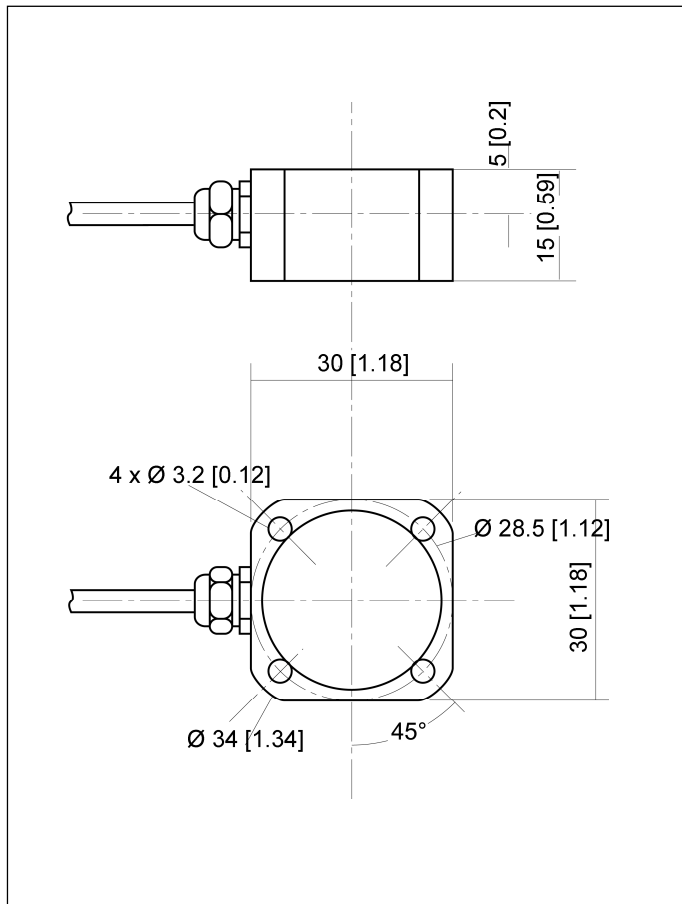

Wiring Schematic

FA101 / FA101-24

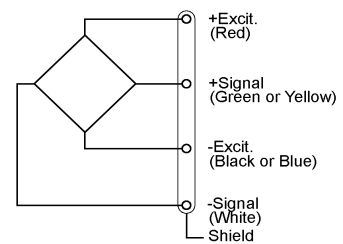

FA101-A1

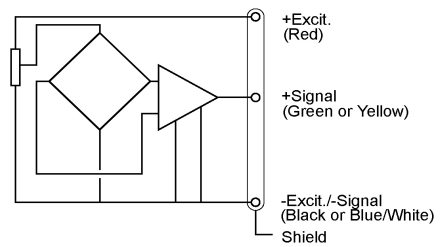

FA101-A2

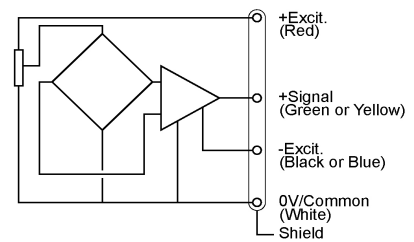

FA101 Accelerometer

OPTIONS

A1	: Monopolar tension
A2	: Bipolar Tension
A3	: Current loop
ET1	: CTR -20 to 100°C [-4 to 212°F] OTR=CTR (Option unavailable with version A3)
ET2	: CTR -40 to 120°C [-40 to 248°F] OTR=CTR (Option unavailable with version A3)
L	: Linearity $\leq \pm 1\%$ F.S.
ZI	: Zero shift $\leq \pm 1\%$ F.S. / 50°C (100°F)
LC"x"	: Additional cable length to standard length (in m) (Note: "X" = Custom value)

ORDERING INFO

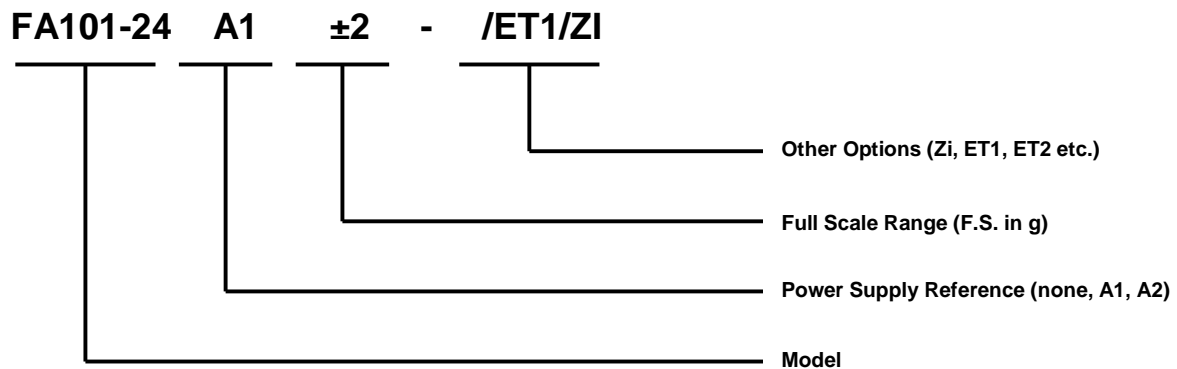

NORTH AMERICA

Measurement Specialties, Inc.
1000 Lucas Way
Hampton, VA 23666
USA
Tel: 1-757-766-1500
Fax: 1-757-766-4297

EUROPE

Measurement Specialties
(Europe), Ltd.
26 Rue des Dames
78340 Les Clayes-Sous-Bois,
France
Tel: +33 (0) 130 79 33 00
Fax: +33 (0) 134 81 03 59

ASIA

北京汇润科贸有限公司
电话: +86 010 5601 8989
+86 010 5601 7979
传真: +86 010 5885 7266
邮箱: sales@aq315.com
<http://www.aq315.com>

The information in this sheet has been carefully reviewed and is believed to be accurate; however, no responsibility is assumed for inaccuracies. Furthermore, this information does not convey to the purchaser of such devices any license under the patent rights to the manufacturer. Measurement Specialties, Inc. reserves the right to make changes without further notice to any product herein. Measurement Specialties, Inc. makes no warranty, representation or guarantee regarding the suitability of its product for any particular purpose, nor does Measurement Specialties, Inc. assume any liability arising out of the application or use of any product or circuit and specifically disclaims any and all liability, including without limitation consequential or incidental damages. Typical parameters can and do vary in different applications. All operating parameters must be validated for each customer application by customer's technical experts. Measurement Specialties, Inc. does not convey any license under its patent rights nor the rights of others.