

## Model 2221D Piezoelectric accelerometer

### Features

- High output, 17 pC/g
- Light weight (12 gm)
- 360° cable orientation
- Low profile
- Vibration measurement on small structures



北京汇润科贸有限公司

电话：+86 010 5601 8989

+86 010 5601 7979

传真：+86 010 5885 7266

邮箱：[sales@aq315.com](mailto:sales@aq315.com)

http://www.aq315.com

### Description

The Endevco® Model 2221D is a piezoelectric accelerometer designed specifically for vibration measurement on small structures and objects. The unit is epoxy sealed and it is ideal for use in a controlled environment. Its light weight (12 gm) effectively minimizes mass loading. The accelerometer is a self-generating device that requires no external power source for operation.

The Model 2221D features Endevco's Piezite® Type P-8 crystal element operating in annular shear mode. This device exhibits excellent output sensitivity stability over time. Signal ground is connected to the outer case of the unit. When used with an isolated mounting screw, the accelerometer is electrically isolated from ground. A low-noise coaxial cable is supplied for error-free operation. The transducer has a centrally located thru bolt, allowing for 360° cable orientation. The unit may also be adhesive mounted if the application permits.

Endevco signal conditioner Models 133 or Oasis 2000 computer-controlled system are recommended for use with this high impedance accelerometer.

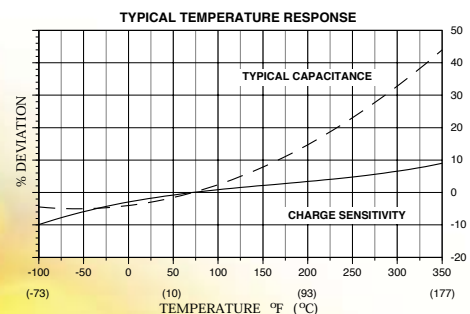
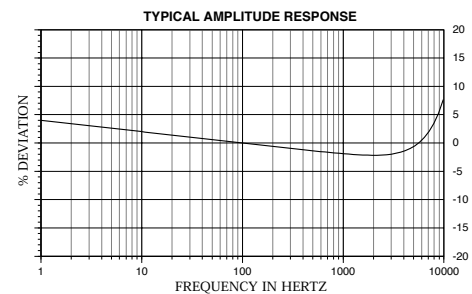
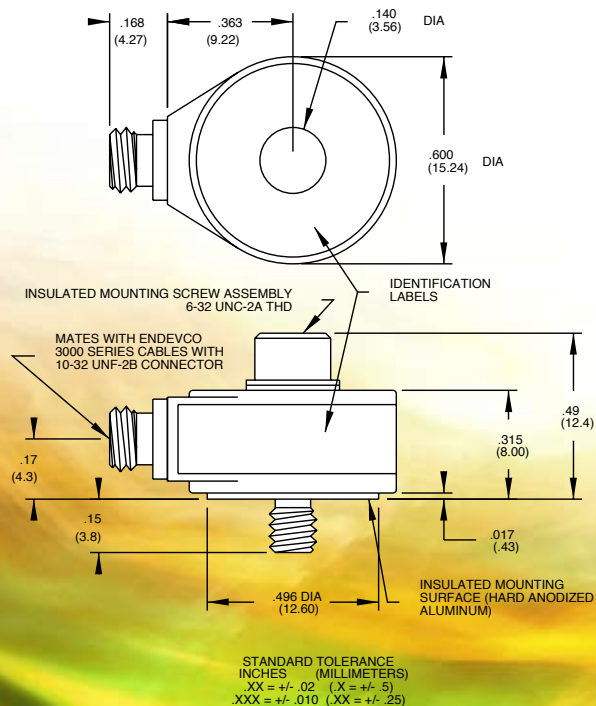

# Model 2221D Piezoelectric accelerometer

Endevco

## SPECIFICATIONS

The following performance specifications conform to ISA-RP-37.2 (1964) and are typical values, referenced at +75°F (+24°C) and 100 Hz, unless otherwise noted. Calibration data, traceable to National Institute of Standards and Technology (NIST), is supplied.

DYNAMIC CHARACTERISTICS	Units	
CHARGE SENSITIVITY		
TYPICAL	pC/g	17.0
MINIMUM	pC/g	13.5
FREQUENCY RESPONSE		
		See Typical Amplitude Response
RESONANCE FREQUENCY		
		32 (Typical)
AMPLITUDE RESPONSE [1]		
± 5%	Hz	1 to 6000
± 1dB	Hz	.1 to 10 000
TEMPERATURE RESPONSE		
		See Typical Curve
TRANSVERSE SENSITIVITY		
		≤ 3
AMPLITUDE LINEARITY [2]		
		1
Per 250 g, 0 to 2500 g		

ELECTRICAL CHARACTERISTICS		
OUTPUT POLARITY		
		Acceleration into the base of the unit produces positive output
RESISTANCE	GΩ	≥ 10
ISOLATION	MΩ	10
CAPACITANCE	pF	900
GROUNDING		
		Signal return connected to case. Case isolated from mounting surface by insulated screw assembly

ENVIRONMENTAL CHARACTERISTICS		
TEMPERATURE RANGE		
		-67°F to +350°F (-55°C to +177°C)
HUMIDITY		
		Epoxy sealed, non-hermetic
SINUSOIDAL VIBRATION LIMIT	g pk	1000
SHOCK LIMIT	g pk	5000
BASE STRAIN SENSITIVITY	equiv. g/μ strain	0.01
THERMAL TRANSIENT SENSITIVITY	equiv. g pk/°F (°C)	0.004 (0.007)

PHYSICAL CHARACTERISTICS		
DIMENSIONS		
		See Outline Drawing
WEIGHT	gm (oz)	12 (0.42)
CASE MATERIAL		
		Stainless Steel
CONNECTOR		
		Coaxial 10-32 thread
MOUNTING TORQUE	lbf-in (Nm)	8 (1)

CALIBRATION		
SUPPLIED:		
CHARGE SENSITIVITY	pC/g	
MAXIMUM TRANSVERSE SENSITIVITY	%	
CAPACITANCE	pF	
FREQUENCY RESPONSE	%	20 Hz to 6 kHz
	dB	8000 Hz to 40 kHz

### INCLUDED ACCESSORIES

Model EHM49	ALLEN WRENCH, 7/64 INCH
Model 2987	ADHESIVE MOUNTING ADAPTER
Model 3090DV-120 (10ft)	CABLE ASSEMBLY
P/N 10207	INSULATED MOUNTING SCREW, 6-32

### OPTIONAL ACCESSORIES

Model 2984M3	ADAPTER STUD 10-32
Model 2984M4	INSULATED ADAPTER STUD, 10-32
Model 2771AM3	IN-LINE CHARGE CONVERTOR FOR USE WITH CONSTANT CURRENT SOURCE
Model 2950M3	TRIAxIAL MOUNTING BLOCK

### NOTES

1. Low-end response of the transducer is a function of its associated electronics.
2. Short duration shock pulses, such as those generated by metal-to-metal impacts, may excite transducer resonance and cause linearity errors. Send for TP290 for more details.
3. Maintain high levels of precision and accuracy using Endevco's factory calibration services. Call Endevco's inside sales force at 800-982-6732 for recommended intervals, pricing and turn-around time for these services as well as for quotations on our standard products.

Continued product improvement necessitates that Endevco reserve the right to modify these specifications without notice. Endevco maintains a program of constant surveillance over all products to ensure a high level of reliability. This program includes attention to reliability factors during product design, the support of stringent Quality Control requirements, and compulsory corrective action procedures. These measures, together with conservative specifications have made the name Endevco synonymous with reliability.

©ENDEVCO CORPORATION. ALL RIGHTS RESERVED 30700 RANCHO VIEJO ROAD, SAN JUAN CAPISTRANO, CA 92675 USA

