

High temperature application accelerometer



Features

- Ex-ATEX
- Corrosion resistant
- Hermetic seal
- Case isolated
- ESD protection
- Reverse wiring protection

Dynamic

Sensitivity, $\pm 10\%$, 25°C	30 pC/g
Acceleration range	500 g peak
Amplitude nonlinearity.....	1%
Frequency response:	
$\pm 5\%$	3 - 5,000 Hz
$\pm 1\text{dB}$	1 - 10,000 Hz
$\pm 3\text{dB}$	0.4 - 14,000 Hz
Resonance frequency.....	32 kHz
Transverse sensitivity, max.....	5% of axial
Temperature response:	
-70°C	-10%
$+260^{\circ}\text{C}$	+10%

Electrical

Power requirement:	Charge output
Output capacitor, max.....	1100 pF
Grounding.....	case isolated, Internally shielded

Environmental

Temperature range.....	-70 to 260°C
Vibration limit.....	500 g peak
Shock limit.....	5,000 g peak
Electromagnetic sensitivity, equiv g, max	70 $\mu\text{g/gauss}$
Sealing	Hermetic
Base strain sensitivity, max.....	0.0002 g/ μstrain

Physical

Sensing element design.....	PZT ceramic/shear
Weight.....	80 grams
Case material.....	304L stainless steel
Mounting.....	1/4 - 28 UNF
Output connector.....	2 pin, MIL-C-5015
Mating connector.....	R6 type
Recommended cabling.....	J10 / J9T2A

Accessories

- 1/4-28 to 1/4-28 mounting stud (or customers specified)
- Calibration certificate

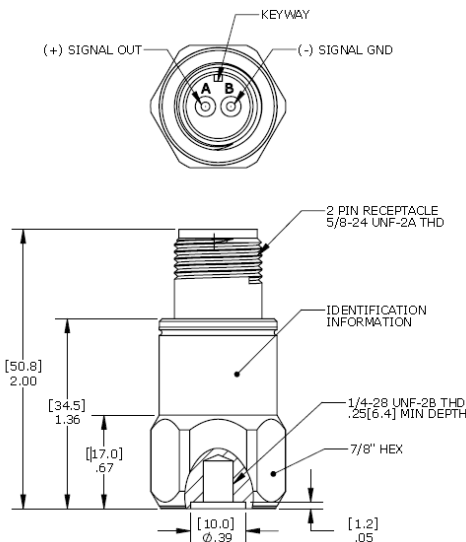

Ordering Information

