

## High temperature application accelerometer



### Features

- Corrosion resistant
- Hermetic seal
- ESD protection

### Dynamic

Sensitivity, $\pm 20\%$ , $25^{\circ}\text{C}$ .....	30 pC/g
Acceleration range .....	2000 g peak
Amplitude nonlinearity.....	1%
Frequency response:	
$\pm 5\%$ .....	3 - 5,000 Hz
$\pm 1\text{dB}$ .....	1 - 10,000 Hz
$\pm 3\text{ dB}$ .....	0.4 - 14,000 Hz
Resonance frequency.....	32 kHz
Transverse sensitivity, max.....	5% of axial
Temperature response:	
$-70^{\circ}\text{C}$ .....	-10%
$+260^{\circ}\text{C}$ .....	+10%

### Electrical

Power requirement: .....	Charge output
Output capacitor, max.....	1100 pF
Grounding.....	case ground

### Environmental

Temperature range.....	$-70$ to $260^{\circ}\text{C}$
Vibration limit.....	2000 g peak
Shock limit.....	5,000 g peak
Electromagnetic sensitivity, equiv g, max .....	70 $\mu\text{g/gauss}$
Sealing .....	Hermetic
Base strain sensitivity, max.....	0.0002 $\mu\text{g/strain}$

### Physical

Sensing element design.....	PZT ceramic/shear
Weight.....	12 grams
Case material.....	304L stainless steel
Mounting.....	10-32 UNF
Output connector.....	10-32
Recommended cabling.....	10-32 to BNC low noise

### Accessories

- 10-32 to 10-32 mounting stud (or customers specified)
- Calibration certificate

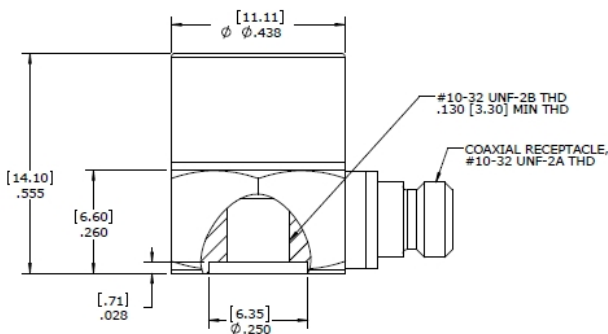
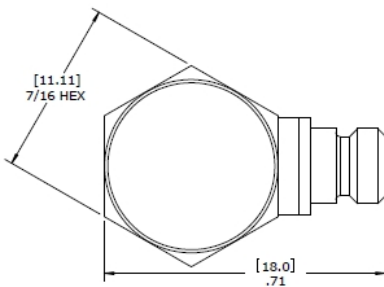

### Ordering Information

